

F 36 54 001 ZS

Hardtop-Erstmontage

BMW Z3 roadster (E36/7)

Fachkenntnisse sind Voraussetzung.

Einbauzeit ca. 1,0 Stunde, die je nach Zustand und Ausstattung des Fahrzeuges abweichen kann.

BMW Parts and Accessories - Installation Instruction

Hardtop - first fitting

BMW Z3 roadster (E36/7)

Instructions de montage des pièces et des accessoires BMW

Montage initial du hardtop

BMW Z3 roadster (E36/7)

BMW Onderdelen en accessoires - Montagehandleiding

Hardtop - eerste montage

BMW Z3 roadster (E36/7)

BMW Delar och tillbehör - Monteringsanvisning

Hardtopmontering

BMW Z3 roadster (E36/7)

Ricambi e accessori BMW - Istruzioni di montaggio

Primo montaggio dell'hardtop

BMW Z3 roadster (E36/7)

BMW piezas y accesorios - instrucciones de montaje

Montaje inicial del techo rígido

BMW Z3 roadster (E36/7)

Peças e Acessórios BMW - Instruções de Montagem

Primeira montagem de "Hardtop"

para os modelos BMW Z3 roadster (E36/7)

Sicherheitshinweise

Die Erstmontage des Hardtops ist ausschließlich durch eine BMW Fachwerkstatt durchzuführen. Nur dort steht entsprechend geschultes Fachpersonal mit den notwendigen Werkzeugen und Hilfsmitteln zur Verfügung.

Für Schäden, die durch Mißachtung der Arbeitsreihenfolgen und der Sicherheitshinweise auftreten, übernimmt BMW keine Haftung. Außerdem erlischt bei unsachgemäßer, von der Montage- und Bedienungsanleitung abweichender Montage und Handhabung der Garantieanspruch gegenüber der BMW AG.

Montagehinweise

Die Montage des Hardtops sollte von zwei Personen durchgeführt werden.

Die Montage- und Einstellmaßnahmen sind nur auf der linken Fahrzeugseite dargestellt. Die Arbeitsschritte auf der rechten Fahrzeugseite müssen sinngemäß in der gleichen Reihenfolge durchgeführt werden.

Allgemeine Hinweise

Pflege- und Wartungshinweise entnehmen Sie bitte der Zusatzbetriebsanleitung Hardtop.

Erforderliches Werkzeug und Hilfsmittel

Hakenschlüssel	(54 21 1 972 684)
Montagelehre	(54 21 9 408 881)
Torx-Steckschlüssel TX40	(54 21 8 410 548 im Lieferumfang enthalten)
Gabelschlüssel SW 24mm	
Gabelringschlüssel SW 10mm	
1/4 Zoll Knarre	
1/4 Zoll Verlängerung	
1/4 Zoll Steckschlüsseleinsatz SW 10mm	
1/4 Zoll Torxeinsatz TX30	
Maßband	
Meßschieber	
Fühllehre	
Schraubensicherung Loctite 243	(83 19 9 407 894)
BMW Gummipflegemittel	
Innensechskantschlüssel SW 2,5mm	

Inhaltsverzeichnis

Kapitel	Seite
1. Teilesatz Hardtop.....	3
2. Vorbereitende Arbeiten.....	4
3. Einstellmöglichkeiten an den Hardtopaufnahmen.....	4
4. Hardtop am Fahrzeug verbauen und einstellen.....	5
5. Empfehlung.....	8

Hardtop - first fitting

BMW Z3 roadster (E 36/7)

Technical knowledge is required
Installation time approx. 1.0 hour, which can vary according to the condition and fittings of the vehicle.

Safety notes

The first fitting of the hardtop is to be carried out only by a BMW specialist workshop. This is where the appropriately trained specialist personnel and necessary tools and auxiliary materials are exclusively available.

BMW accepts no liability for damage which occurs as a result of not following the work sequence and safety instructions. In addition, any warranty claim against BMW AG is extinguished in the event of improper fitting and handling which diverges from the installation and operating instructions.

Assembly notes

Fitting of the hardtop should be done by two people.

The steps taken for fitting and adjustment are shown only on the left-hand side of the vehicle. The work steps on the right-hand side of the vehicle must be carried out in the equivalent logical sequence.

General notes

Please refer to the supplementary owner's handbook for the hardtop for care and maintenance instructions.

Required tools and auxiliary materials

Hook spanner (54 21 1 972 684)
Mounting gauge (54 21 9 408 881)
Torx socket wrench TX40 (54 21 8 410 548 included in parts package)
Open-ended spanner SW 24 mm
Combination spanner SW 10 mm
1/4 inch ratchet
1/4 inch extension
1/4 inch socket-wrench insert SW 10 mm
1/4 inch Torx insert TX30
Tape measure
Calliper rule
Feeler gauge
Screw locking paste Loctite 243 (83 19 9 407 894)
BMW rubber preserver
Hexagon socket-screw key SW 2.5 mm

Contents

Section

1. Parts kit for hardtop
2. Preparatory work
3. Adjustment possibilities to the hardtop support fixtures
4. Fit hardtop to vehicle and make adjustments
5. Recommendation

1. Parts kit for hardtop

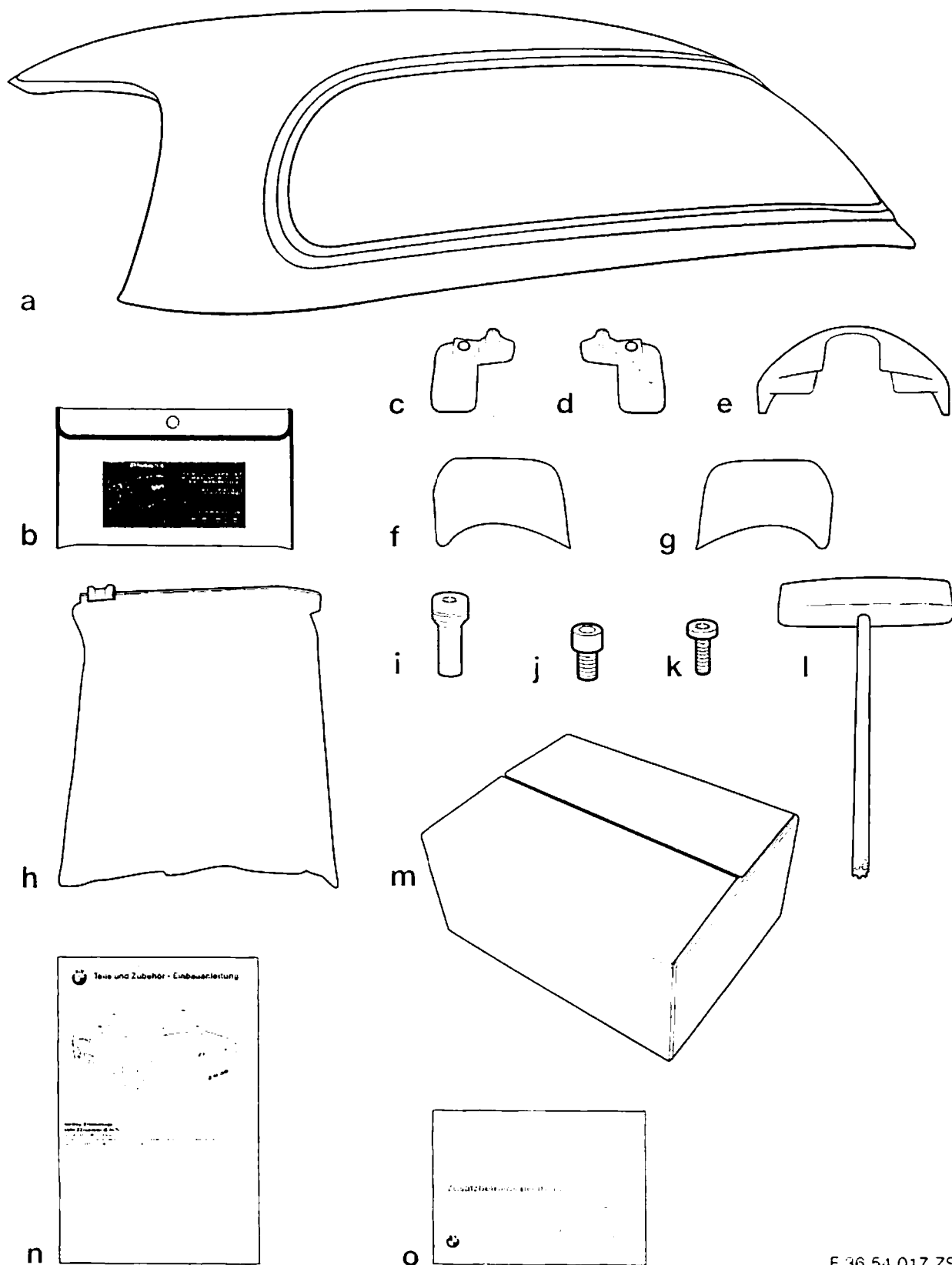

F 36 54 017 ZS

- a Hardtop (1x)
- b Protective cloth (1x)
- c Base plate left (preassembled) (1x)
- d Base plate right (preassembled) (1x)
- e Covering for lock (2x)
- f Covering for roof liner left (1x)
- g Covering for roof liner right (1x)
- h Cover with wall bracket (1x)

- i Special screw for hardtop attachment front (M8x1, 25x22.35 Torx 40) (2x)
- j Screw for covering (M4x10) (4x)
- k Screw for base plate/hardtop (preassembled) (6x)
- l Socket wrench (1x)
- m Installation kit for hardtop substructure (1x)
- n Installation instructions (1x)
- o Supplementary owner's handbook (1x)

F 36 54 017 ZS

2. Preparatory work

Remove the two covers for the hardtop supports if they have already been fitted (see installation instructions "Substructure for Hardtop").

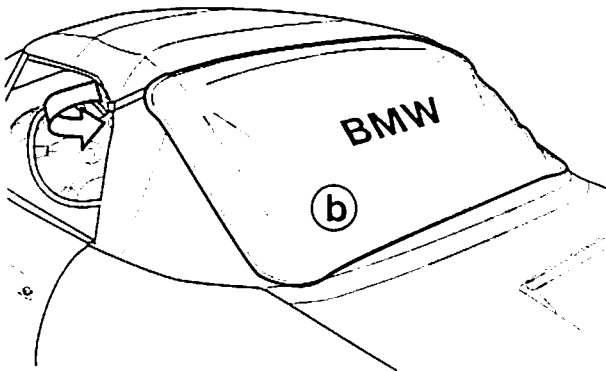

F 36 54 018 ZS

F 36 54 018 ZS

Take the protective cloth (b) from the parts kit and hook it to the convertible top bow. Place convertible top in convertible top compartment, (if necessary carefully placing the protective cloth in the folds of the rear window to avoid permanent damage to the rear window), and fold down the unlocking lever on the convertible-top frame.

Note

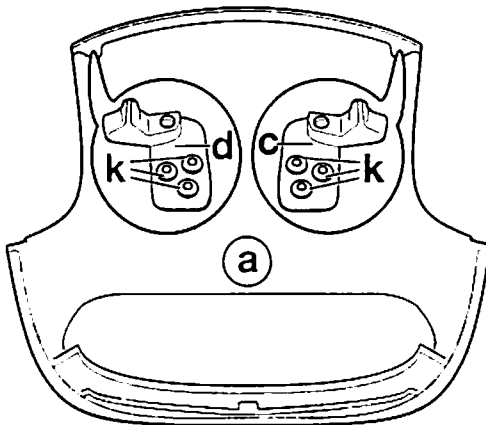

F 36 54 019 ZS

F 36 54 019 ZS

The base plates (c and d) on the left and right on the hardtop (a) are already preassembled and for adjustment purposes must be easily movable. If necessary loosen the screws (k) a little.

3. Adjustment possibilities to the hardtop support fixtures

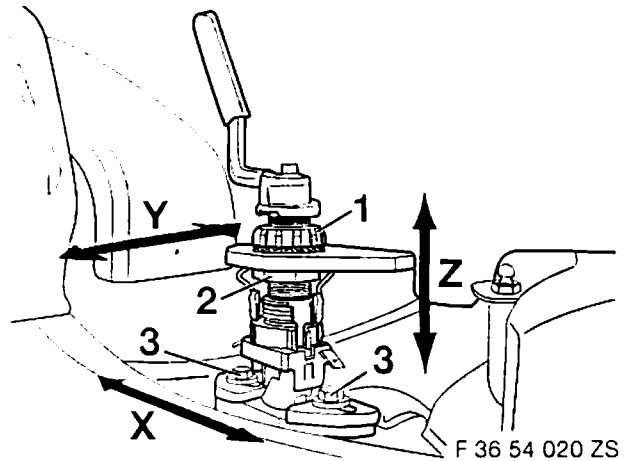

F 36 54 020 ZS

Loosen groove nut (1). Adjustment in Y direction possible (at right angles to vehicle longitudinal axis). Loosen groove nut (1) and with nut (2) adjust the vertical distance (Z) between hardtop (a) and vehicle. Loosen screws (3), adjustment possible in X direction (longitudinal axis of vehicle).

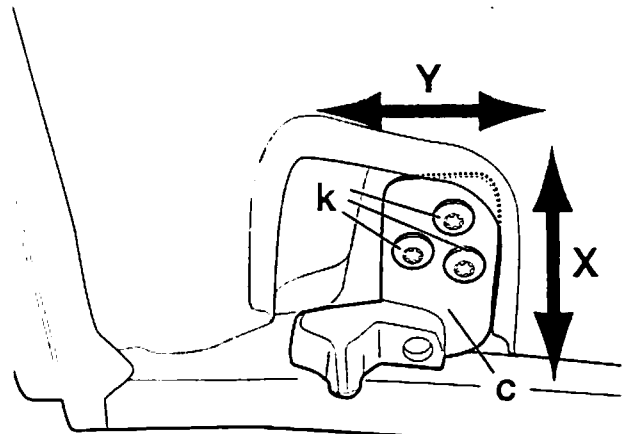

F 36 54 021 ZS

F 36 54 021 ZS

The base plate (c) is movable in Y direction (at right-angles to vehicle longitudinal axis) or X direction (longitudinal axis of vehicle) as appropriate.

4. Fit hardtop to vehicle and make adjustments

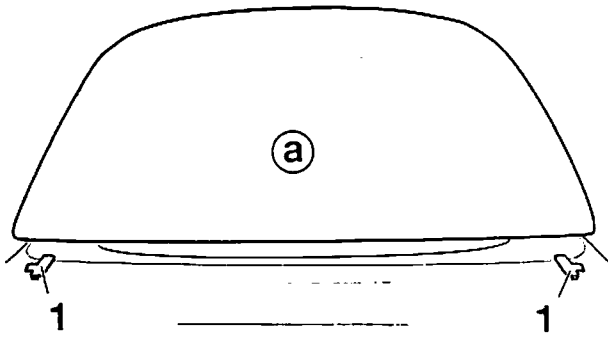

F 36 54 022 ZS

F 36 54 022 ZS

Put mounting gauge (1) on the left and right-hand side of the vehicle and place the hardtop (a) on the vehicle.

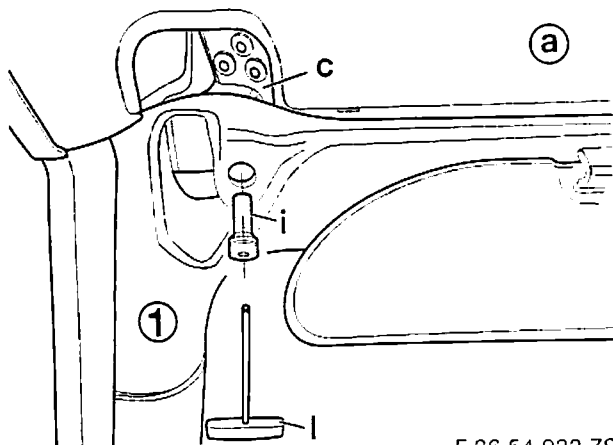

F 36 54 023 ZS

F 36 54 023 ZS

Insert screws (i) in the windscreen panel (1) and screw them into the base plate (c) of the hardtop (a) with socket wrench (l) for 1-2 thread turns.

Note

The two screws (i) remain in the windscreen panel (1) even when the hardtop (a) is subsequently dismantled.

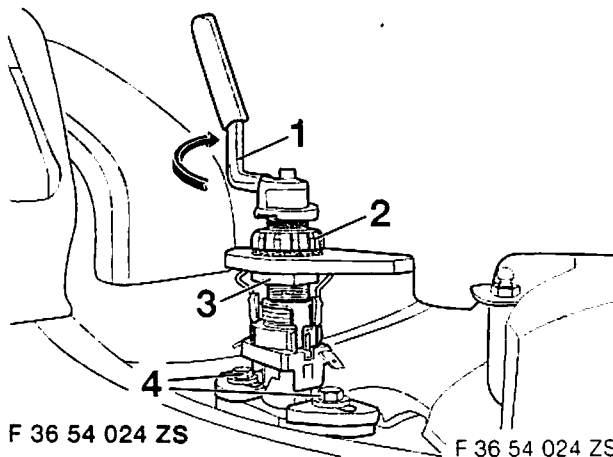

F 36 54 024 ZS

F 36 54 024 ZS

Lock the lever (1) in the direction of the arrow. Loosen grooved nut (2) and nut (3) away from each other. Loosen the two screws (4) also.

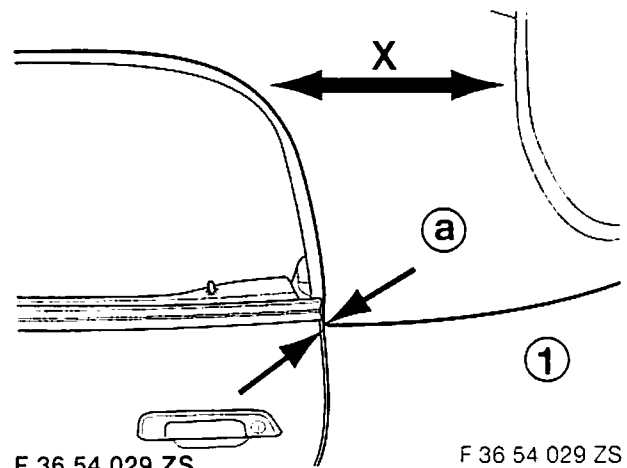

F 36 54 029 ZS

F 36 54 029 ZS

Move hardtop (a) in direction (X) until the edge of the B-pillar of the hardtop (a) aligns with the edge of the vehicle side panel (1) (see arrows).

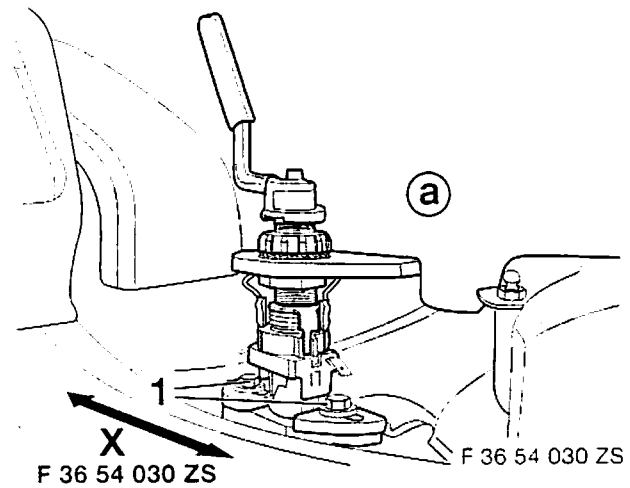

F 36 54 030 ZS

F 36 54 030 ZS

Tighten screws (1) of the rear hardtop mounting.

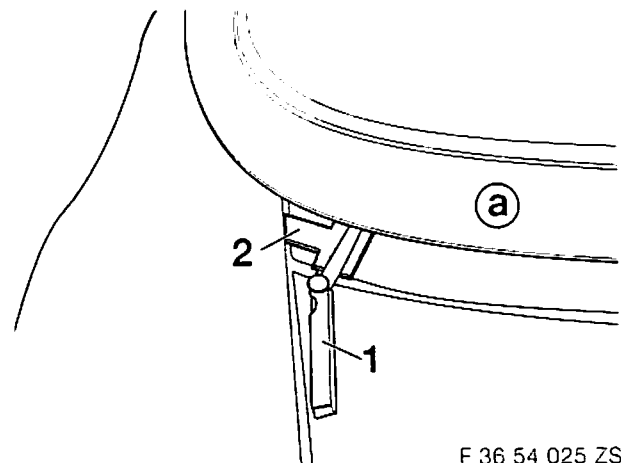

F 36 54 025 ZS

F 36 54 025 ZS

Insert feeler gauge (1) between mounting gauge (2) and the edge of the hardtop (a) and check size of gap on both sides.
Size of gap = 0.20 mm.

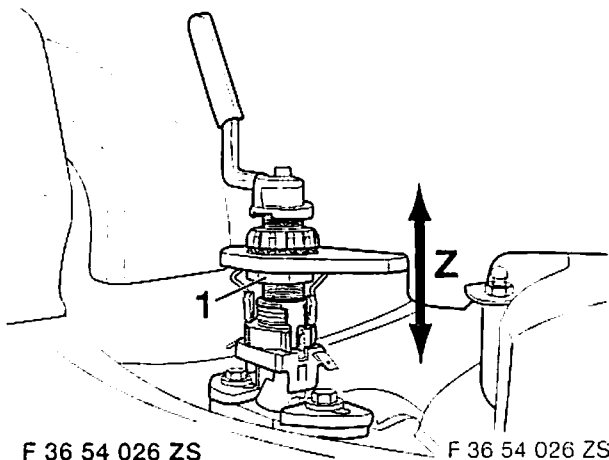

F 36 54 026 ZS

F 36 54 026 ZS

Make the adjustment at the nut (1) in direction Z until the above-mentioned gap size is obtained.

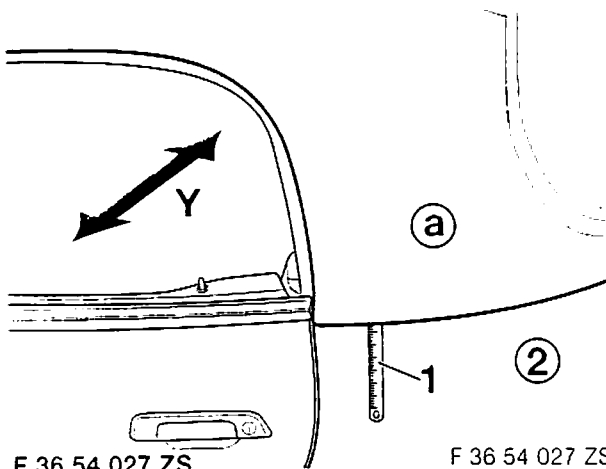

F 36 54 027 ZS

F 36 54 027 ZS

Place tape measure (1) underneath the hardtop (a) on the side panel (2). Move hardtop (a) laterally in direction Y until the same value is given on the tape measure (1) on left and right.

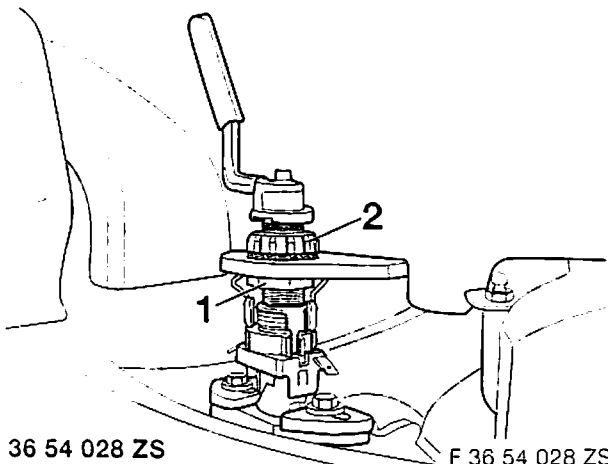

F 36 54 028 ZS

F 36 54 028 ZS

Hold up nut (1) and lock grooved nut (2) with hook spanner.
If necessary check adjustments in directions Y and Z once again.

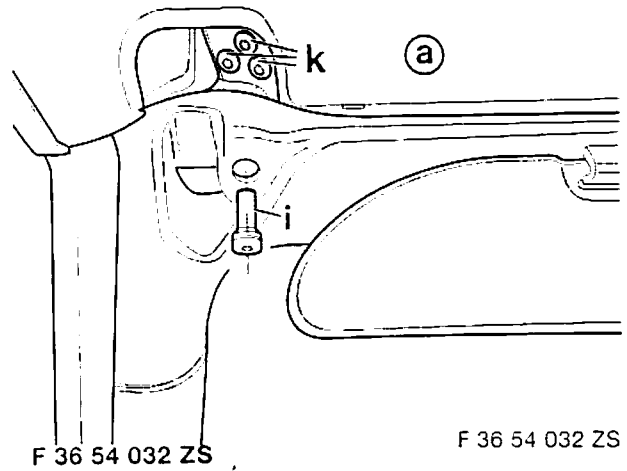

F 36 54 032 ZS

F 36 54 032 ZS

Tighten screws (k and i) of the front hardtop mounting on the left and right of the vehicle.

All adjustment settings are now to be checked and if necessary to be corrected.

Dismount the hardtop in the reverse sequence of the way in which it was installed.

Remove the mounting gauge.

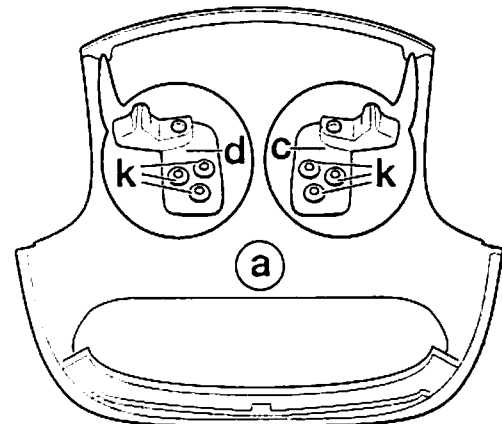

F 36 54 019 ZS

F 36 54 019 ZS

Screw out one of the screws (k) in the hardtop (a), coat it with Loctite and screw it in again. Proceed in the same way with the remaining screws (k).

Caution

The settings of the base plates (c and d) in relation to the hardtop (a) may not be changed.

Tightening torque of the screws (k):
9-11 Nm.

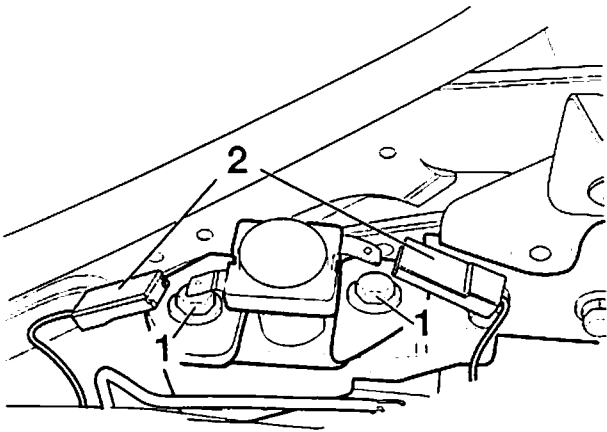

F 36 54 033 ZS

F 36 54 033 ZS

Screw out one of the screws (1) in the hardtop support, coat it with Loctite and screw it back. Proceed in the same way with the remaining screws.

Caution

The setting of the hardtop support may not be changed.

Tightening torque of the screws (1): 9 Nm.

Attach plug connector (2) of the adapter cable on the hardtop support.

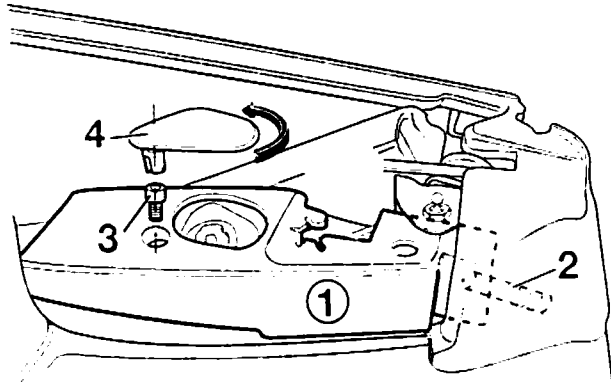

F 36 54 034 ZS

F 36 54 034 ZS

Place covering (1) on the set screw of the main pivot bracket (2) of the soft top and screw the covering (1) on to the hardtop support with screw (3). Insert covering cap (4) in the covering (1) and twist it in the direction of the arrow until the opening is no longer covered.

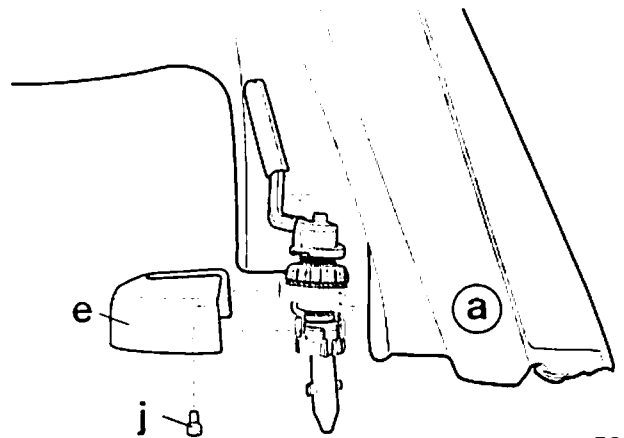

F 36 54 035 ZS

F 36 54 035 ZS

Screw on covering (e) for lock with screws (j) to hardtop (a) on left and right.

Tightening torque of the screws (j): 4 - 6 Nm.

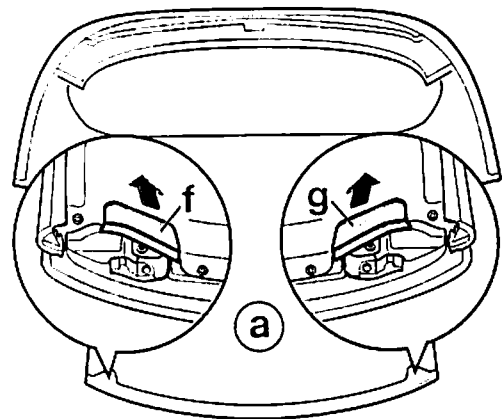

F 36 54 036 ZS

F 36 54 036 ZS

Place coverings (f and g) on roofliner of the hardtop (a) on left and right in the direction of the arrows.

Clean extensively the mounting surfaces of the hardtop on the vehicle and treat the seals of the hardtop with BMW rubber preserver.

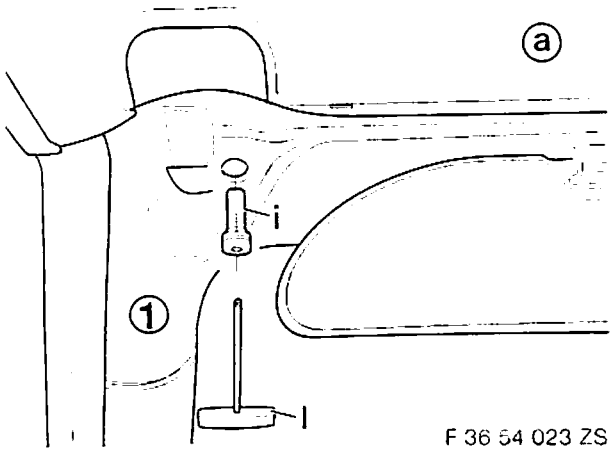

F 36 54 023 ZS

F 36 54 023 ZS

Place hardtop (a) on the vehicle and using the socket wrench (l) screw in the screws (i), located on the left and right in the windscreen panel, by two to three thread turns.

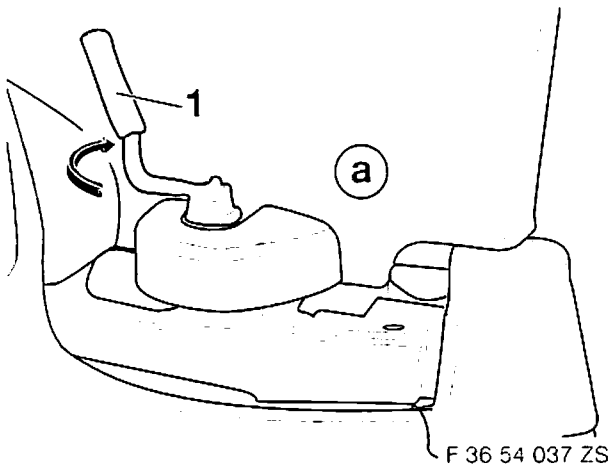

F 36 54 037 ZS

F 36 54 037 ZS

Lock the locking lever (1) of the hardtop in the direction of the arrow as far as possible.

Tighten screws (i) with the socket wrench (l).

Caution

The screws (i) may not be secured with Loctite.

The screws (i) are to be checked again after approx. 50 to 100 km. Please instruct your customers accordingly or draw their attention to the note to this effect in the supplementary owner's manual.

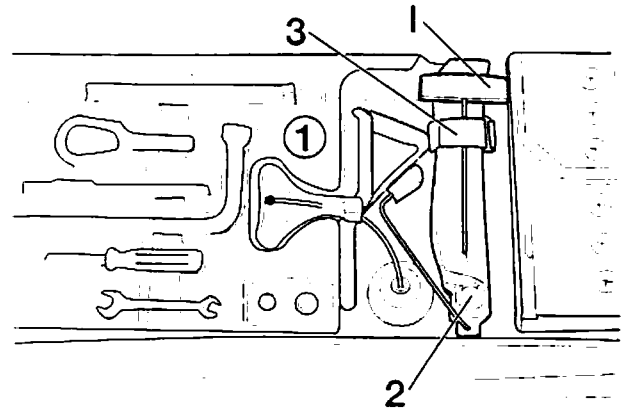

F 36 54 038 ZS

F 36 54 038 ZS

The socket wrench mounting key (l) is to be attached with the velcro fastener (3) in the tool kit box (1) above the car jack (2).

5. Recommendation

We recommend that the customer is shown once the installation and dismantling of the hardtop on handing over the vehicle to him.

Subject to technical modification.

Wichtige Information!

Verwenden Sie zu Ihrer eigenen Sicherheit ausschließlich
Zubehörprodukte, die von BMW freigegeben sind.

Für von BMW nicht freigegebene Zubehörprodukte jedweder
Art übernimmt BMW keine Haftung.

**Weiteres BMW Zubehör,
um aus einem BMW Ihren BMW zu machen,
hält Ihr BMW Händler für Sie bereit.**

Important information!

For your own safety please use only accessory products
released by BMW.

BMW will not guarantee for products of any kind not
released by BMW.

**To turn a BMW
into your very own BMW your BMW dealer
will provide you with a wide range of BMW
accessories.**